



230 WBL 01

FLASHING WARNING BEACON

FOR USE IN INDUSTRIAL ENVIRONMENTS

The flashing warning beacon is used to visually indicate alarm signals as well as incoming calls at intercom stations. It is directly controlled by the INDUSTRONIC system.

The robust beacon can be installed both indoors and outdoors.



- Weather-proof flashing warning beacon for industrial environments
- Degree of protection IP54
- Sturdy metal housing
- Impact-proof lens
- Flash energy 5 Joule
- Universal application possibilities

MECHANICAL DATA

Housing material	Aluminum
Lens material	Polycarbonate (PC)
Width x height	54 mm x 200 mm (2.13" x 7.87")
Cable gland	M20
Weight	Approx. 0.3 kg (approx. 0.66 lbs)
Lens colors	Orange, Yellow, Red, White (other colors upon request)

ELECTRICAL DATA

Operating voltage range	185 V AC to 255 V AC
Current consumption	70 mA
Flash energy	5 Joule
Flash rate	1 Hz

ENVIRONMENTAL REQUIREMENTS AND STANDARDS

Ambient temperature during operation	-30 °C to +55 °C (-22 °F to +131 °F)
Degree of protection	IP54 (vertical mounting)

DIMENSIONS

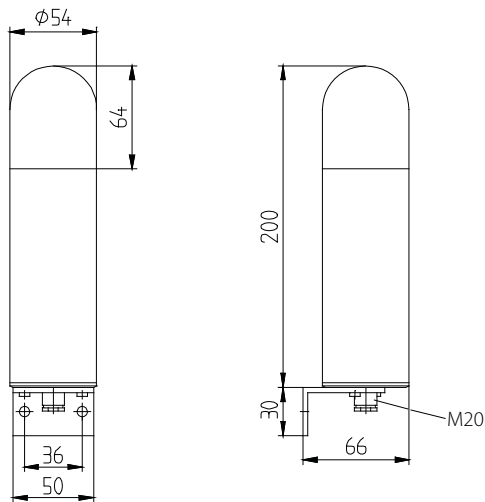

TYPE OVERVIEW

Lens Color	Type	Type Number
White	230 WBL 01/WH	070-000-043/WH
Orange	230 WBL 01/OG	070-000-043/OG
Red	230 WBL 01/RD	070-000-043/RD
Yellow	230 WBL 01/YE	070-000-043/YE

APPLICATION

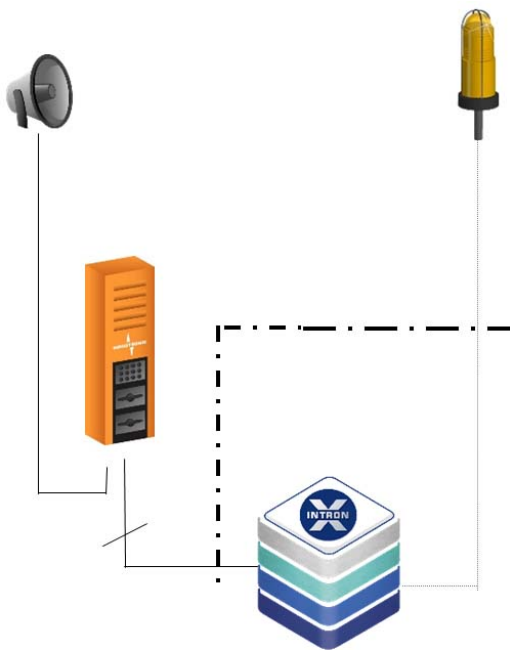

Call Signaling at Intercom Stations

The flashing warning beacon starts to flash, as soon as the intercom station receives a call. The signaling stops, as soon as the incoming call has been accepted or the pre-programmed time has elapsed.

Alarm Signaling

The flashing warning beacon is activated for the duration of the alarm. It is connected to and controlled via the INDUSTRONIC system.

© INDUSTRONIC